

D Vor Montage bitte Gebrauchsanleitung lesen!

I Prima del montaggio leggere per favore le istruzioni per l'uso!

F Prière de lire le mode d'emploi avant de procéder au montage!

GB Please read the instructions of use prior to starting installation work!

ESF3 / ESF2

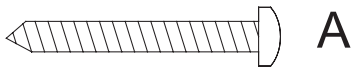

A

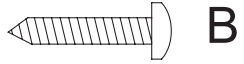

B



C

I

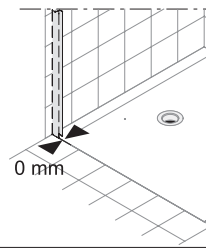

0 mm

II

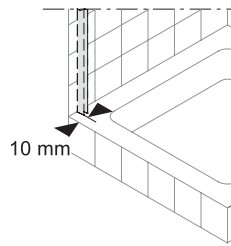

10 mm

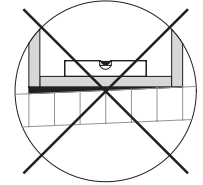

III

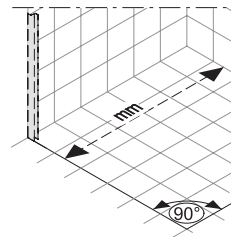

90°

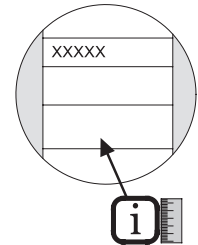

1

I	X = 0 mm
II	X = 10 mm

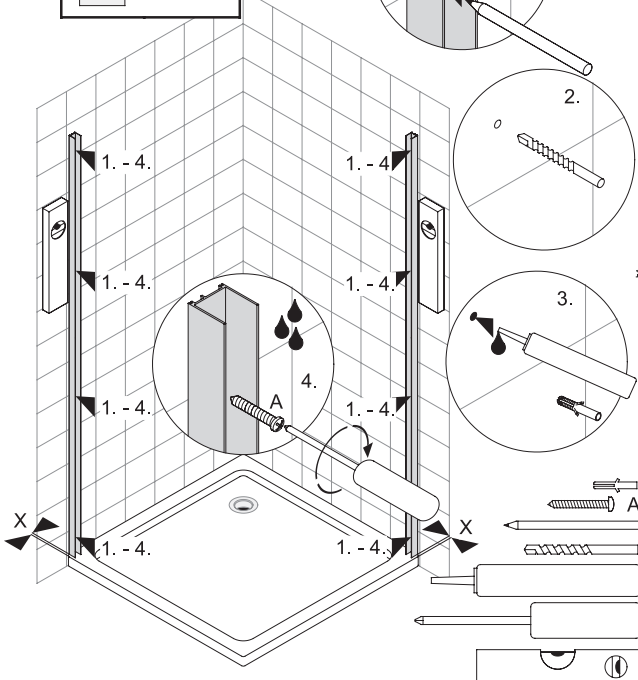
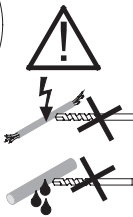
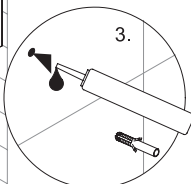
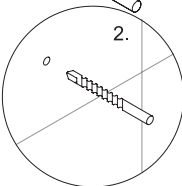
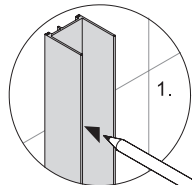

1b

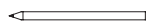
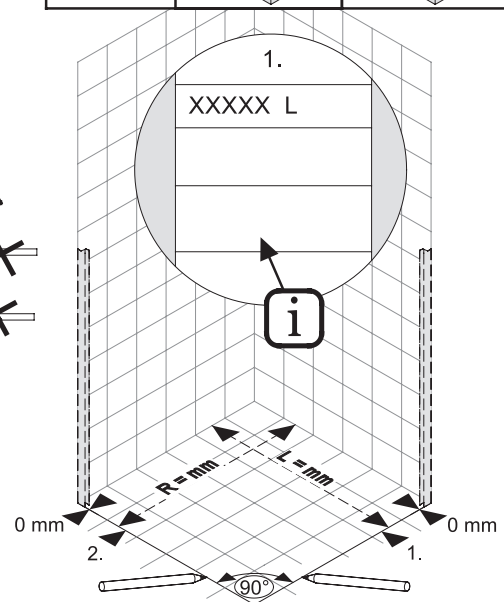
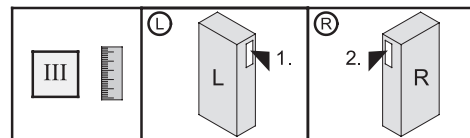

2

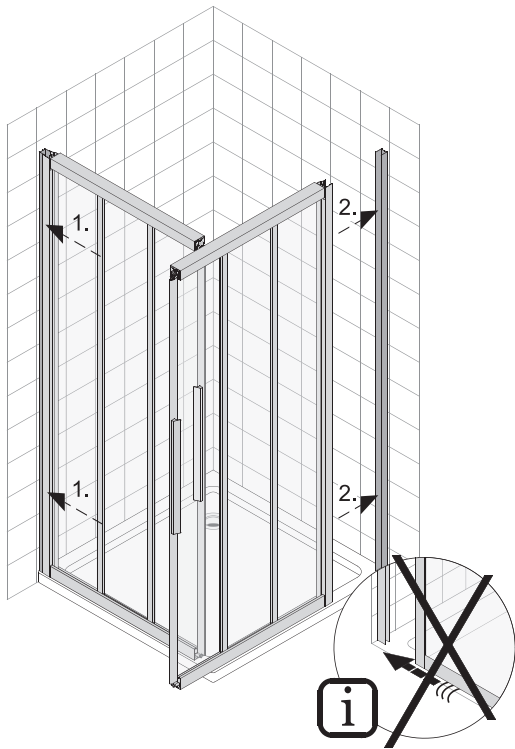

3

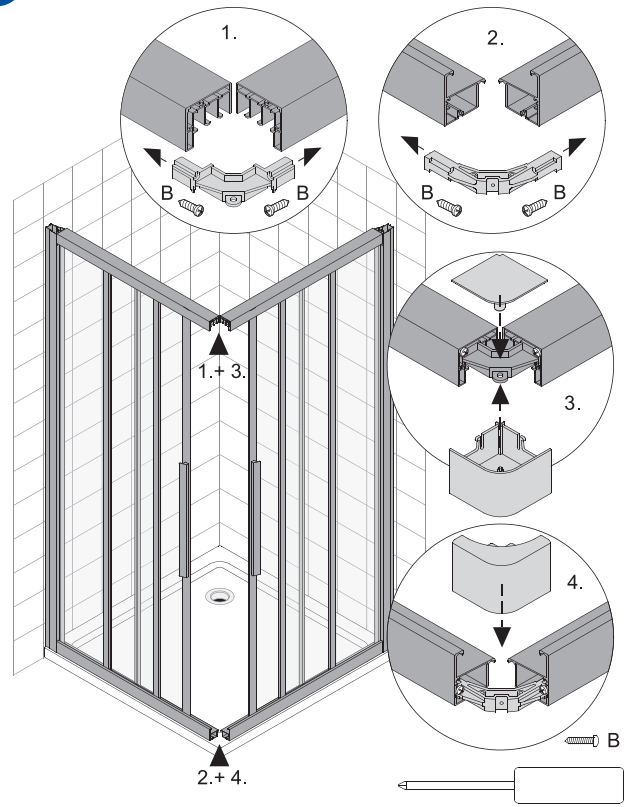

4

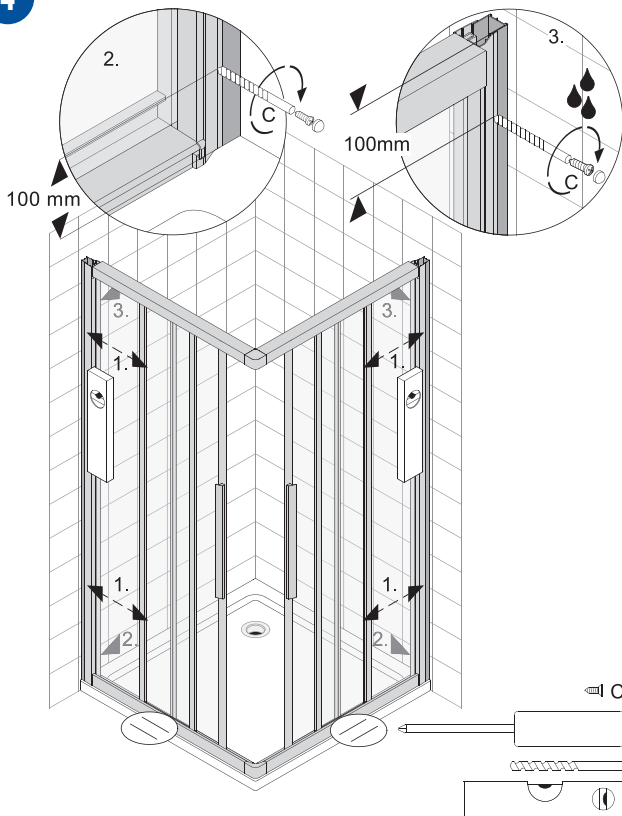

5

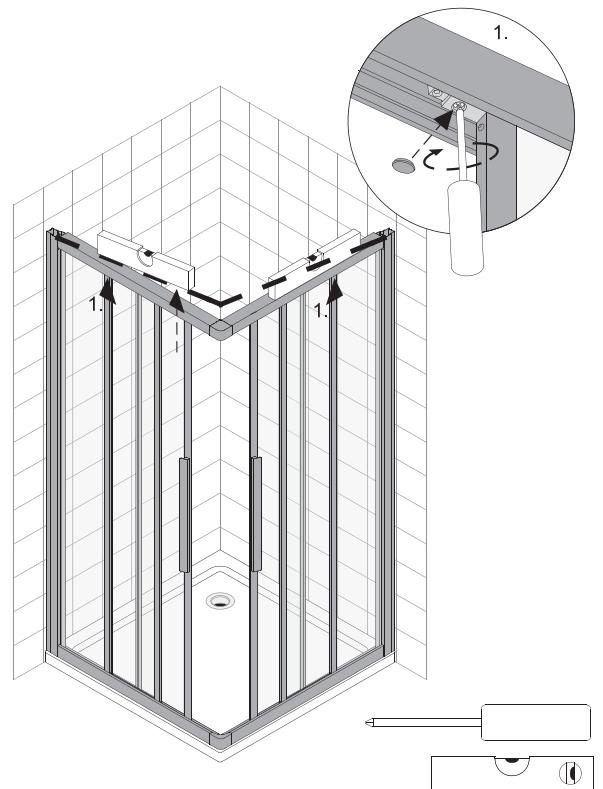

6

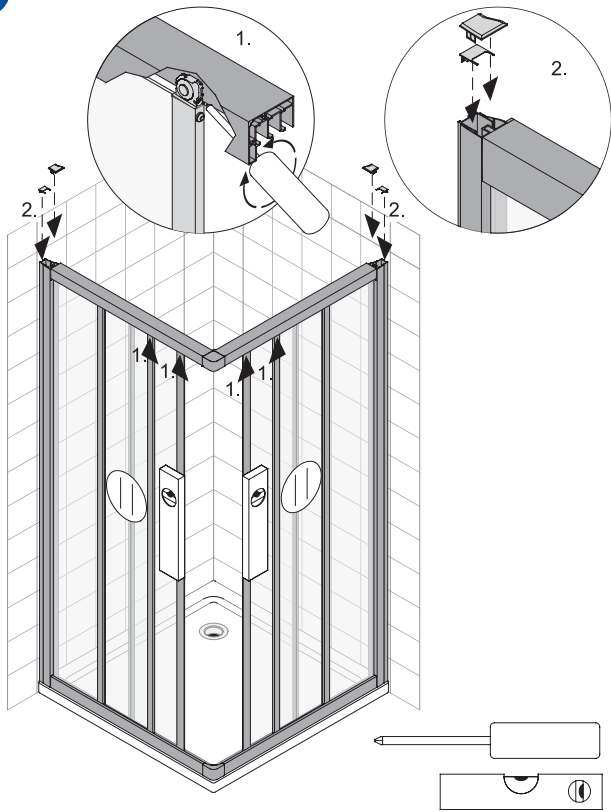

7

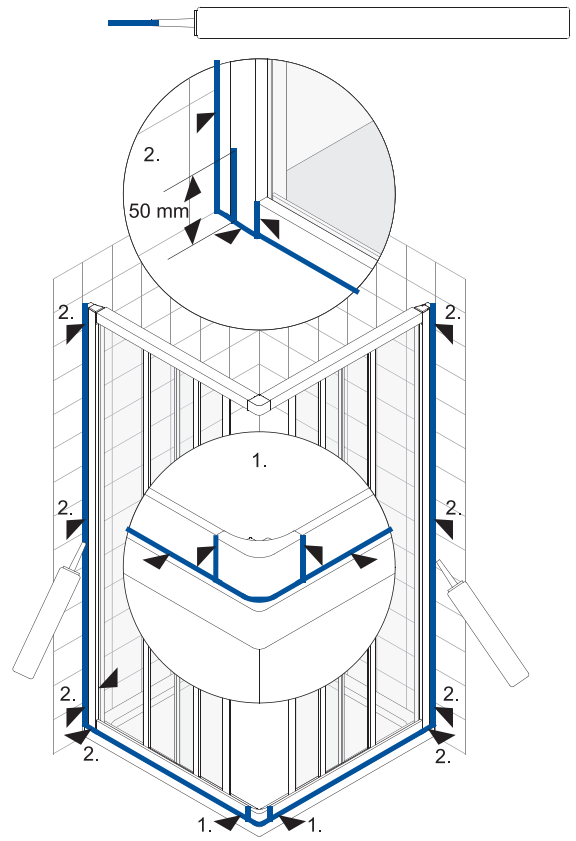

8

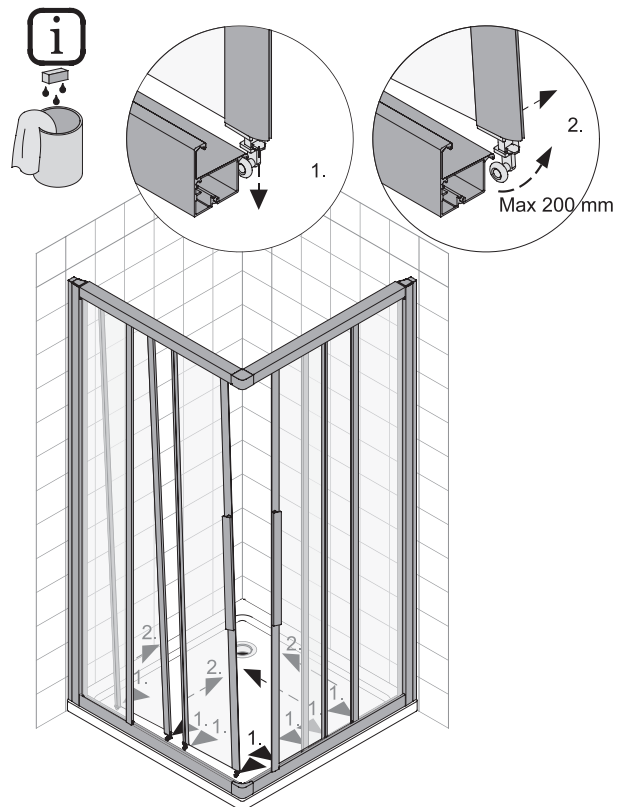
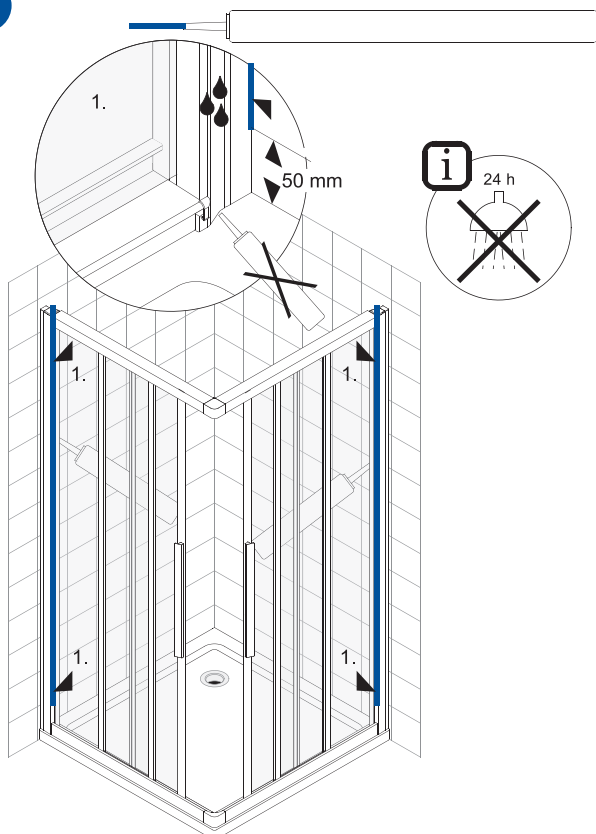

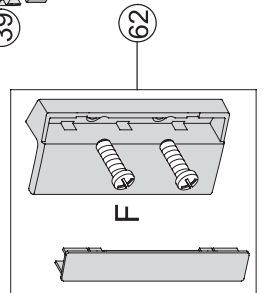
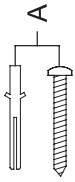
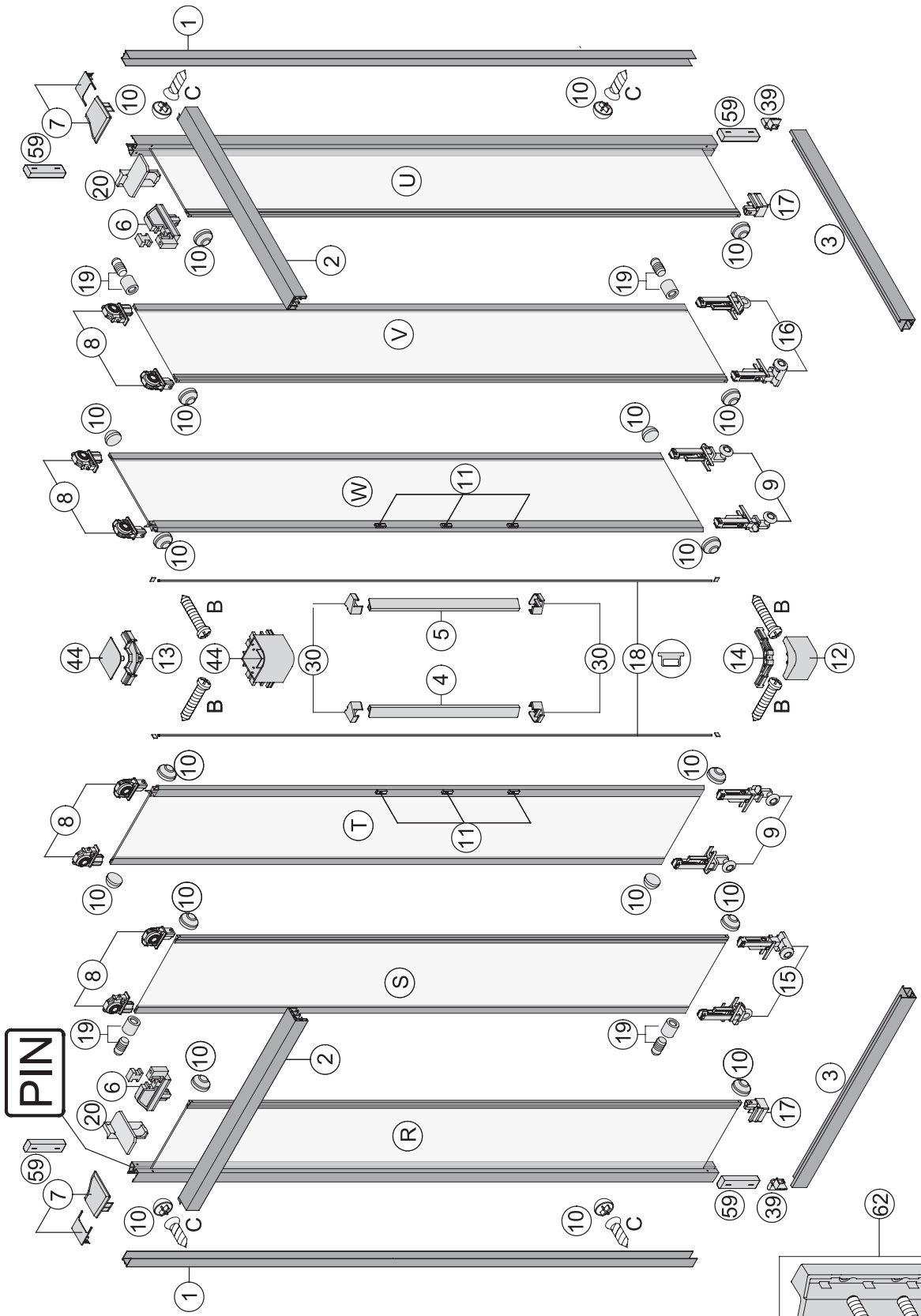
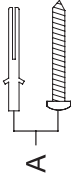

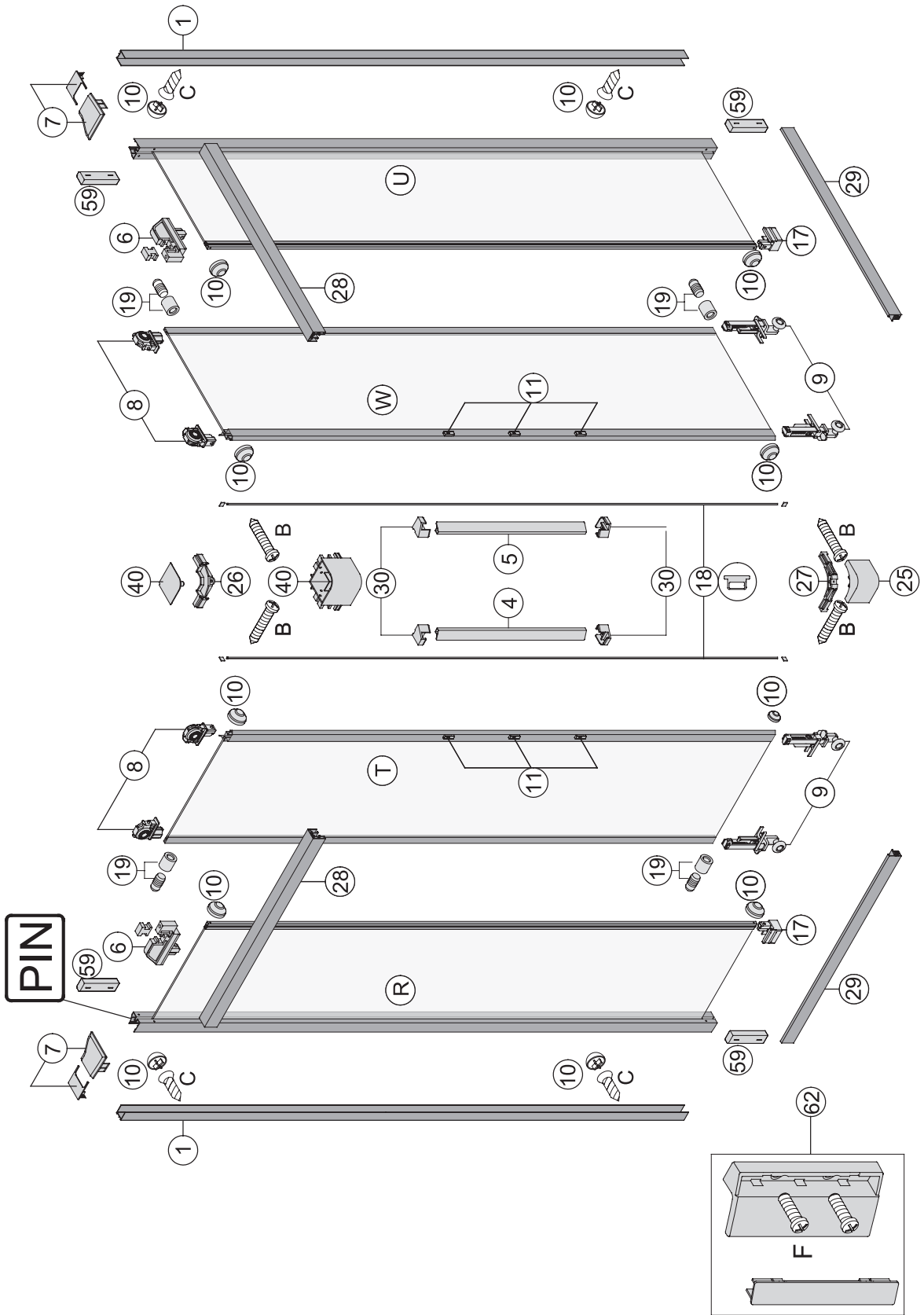
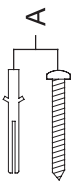
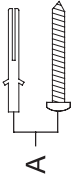

 PIN: 0000
 123456789012345678
 123456789012

→ Ersatzteil / Pièce de rechange / Parte di ricambio / spare part

Technische Änderungen behalten wir uns vor.
 Für Druckfehler oder technische Verwechslungen
 übernehmen wir keine Gewähr.

Nous nous réservons le droit de procéder à des
 modifications techniques. Nous n'assurons pas
 de responsabilité pour des erreurs techniques
 ou des fautes d'impression.

Ci riserviamo il diritto di apportare modifiche tecniche
 senza obbligo di preavviso. Decliniamo ogni responsabilità
 per errori in fase di stampa riguardanti i prodotti e/o
 loro specifiche tecniche.

We reserve the right to technical amendments.
 We do not take responsibility for printing errors
 or technical confusions.